



Ben Haest
Managing Director
Quality Electronics Design S.A.
Luxembourg

Dave Galyardt
Director of Marketing
LDS-Dactron
Fremont, California

Integrating and Automating Complex Vibration Test Systems Using ActiveX Software

Production lines can reduce costs and enhance flexibility by using a standardized, software-base solution to replace expensive, dedicated hardware

Overview:

A major manufacturer of automotive airbag deployment sensors had a need to integrate and automate their product testing to ensure the highest product quality and an efficient production process. Testing verifies the proper operation of the airbag sensors under simulated crash conditions. The equipment used in the testing of the sensors includes a long stroke shaker, a controller for the shaker system, and data acquisition equipment to position the shaker head and capture data from the sensor itself.

Most vibration control systems are stand-alone devices. Even when they have an ActiveX® interface they do not offer the required functionality for integration into a production line. This limitation results because the ActiveX interface was designed for use as a remote control interface and not for integration into an automated test system. A production line application requires an ActiveX interface with standard capabilities for status reporting, error handling, exchange of measured and computed test data, programmable alarm limits, an open data structure, etc.

In the following example, the vibration controller functions as the core of an intelligent measurement system, which is integrated into an automated test system via a standardized ActiveX® interface. This solution reduces test costs and improves product throughput, as described below.

System Goals:

To function as an intelligent measurement system in an automated test network, the vibration control system must integrate four essential functions:

- 1) It must automatically control and check the head position of the long-stroke shaker.
- 2) It must control shock tests up to 100g.
- 3) It must operate synchronously with an autonomous measurement system that acquires data concurrently with the shock pulse output by the vibration control system.
- 4) It must ensure galvanic separation between the control system, the measurement system and the power amplifier of the shaker.

Design Concept

There are two control loops for the shaker. The first loop provides DC regulation for static positioning of the shaker head. The second provides AC control for shock vibration profiles. The two loops function independently but the power amplifier integrates the output signals from both control loops by summing the DC and AC signals internally. Figure 1 below shows a schematic of the entire test system.

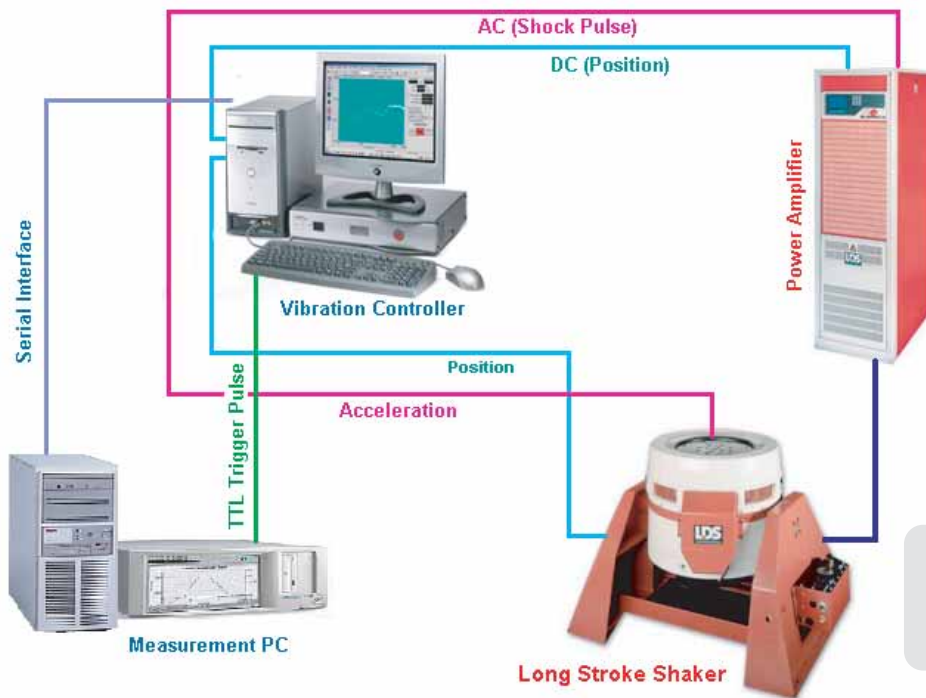

Figure 1. The long stroke shaker is controlled by two loops. One loop controls the static position for the shaker head and the second controls the shock vibration

1) Static Positioning

The shaker is a long-stroke system without a rest zero-position for the shaker head. It does not incorporate a spring that returns the armature to zero-position when current ceases to flow through the armature coil. The shaker does incorporate a displacement sensor that measures the absolute position of the armature. The measurement signal has a -10 Volt to +10 Volt range calibrated over the entire displacement of the shaker. To measure the position signal, the system uses an industry standard PCI measurement card with multiple analog/digital inputs and outputs.

The measurement card generates a DC signal that feeds through an isolation amplifier into the power amplifier. The power amplifier drives DC current through the armature coil of the shaker. This control permits precise positioning of the armature and test fixture and makes it possible to use the full stroke capability of the shaker.

The technical challenge to accurate positioning is that the counteracting and friction forces generated by the shaker vary according to the position of the armature. The head-positioning control loop, therefore, has to be precisely calibrated at different positions across the shaker's displacement.

2) Shock Control

Most vibration control systems available today use a dedicated hardware/software solution for closed-loop shock testing. If the vibration controller can only perform the dedicated shaker control function, then it adds expense and decreases the flexibility of the total test system.

In this case, a master program coordinates both the head-positioning and the shock vibration control loops. Figure 2 shows the user interface for the master program. This program interacts with an LDS-Dactron "LASER Shaker Control System" through a standard set of ActiveX programming tools included with LDS-Dactron's NET-Integrator library. NET-Integrator allows an ActiveX program, such as Visual Basic, C++, LabView, or many others, to communicate with and command the LASER Shaker Controller. For, example, the master test program can command the LASER to start a test, change the test level, pause a test, etc. Both the LASER Shaker Control software and the custom master test software run under Windows 2000.

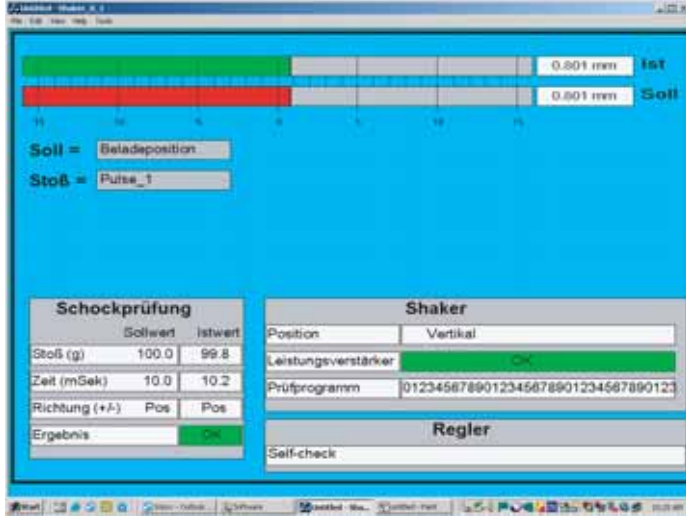

Figure 2. The user interface of the master program for the airbag sensor shock test system. ActiveX commands from the LDS-Dactron NET-Integrator library allow the master program to set up the vibration control system output and report back test results. The two upper bars show the measured and target position of the shaker head. The shock pulse results are reported at the bottom left of the screen together with the settings from the Dactron shock project file. Specific test documentation appears in the dialog box in the bottom right side of the screen.

To minimize control error, the vibration controller measures the test article acceleration in real-time and uses this signal as the input for the control loop. After each shock, the controller calculates a new drive signal by comparing the measured acceleration with the reference shock pulse (typically a half-sine wave). The drive signal is updated to account for any errors between the desired output pulse and the measured acceleration. Then a new drive signal is output to the shaker. Typically this process of control convergence is done during a pre-test, at low excitation levels. During production testing, the drive signal is continuously monitored and updated when needed to assure very precise pre-defined shock pulses.

During testing, the acceleration data is transmitted to the host PC and then to the master test program through the ActiveX interface.

The event signal output by the COLA channel consists of a TTL pulse synchronized with the output of shock drive signal from the vibration control system. A typical TTL trigger pulse and a shock vibration pulse appear in Figure 4. An auxiliary measurement system uses the TTL pulse as trigger to start data acquisition. The TTL event signal provided by the vibration controller eliminates the need for additional dedicated hardware/software just to accurately synchronize the measurement chain.

3) Shock Synchronization

Another requirement of the airbag sensor testing is the synchronization of auxiliary data acquisition systems with the shock pulse output on the shaker system. To do this automation task many vibration controllers would also require dedicated hardware/software to synchronize measurements with the shock pulse. The solution here was to handle this task through a special event pulse generated by control system's COLA output. Figure 3 illustrates how the COLA signal from the vibration controller is used to trigger the data acquisition on the measurement system.

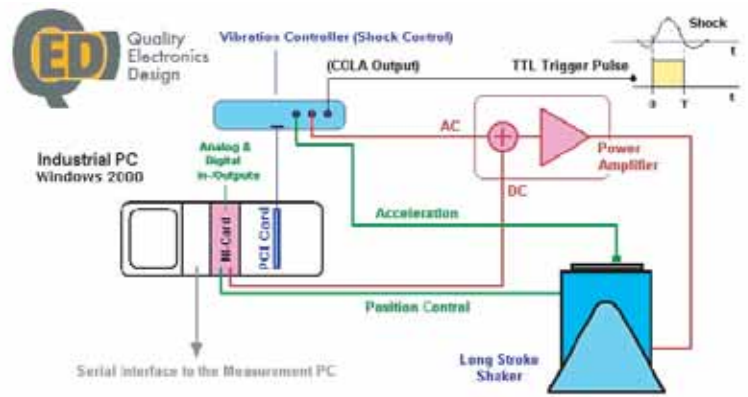

Figure 3. The vibration controller's COLA output sends out a TTL pulse coincident with the start of the shock vibration pulse to enable synchronization of data acquisition with the shock event on the shaker system.

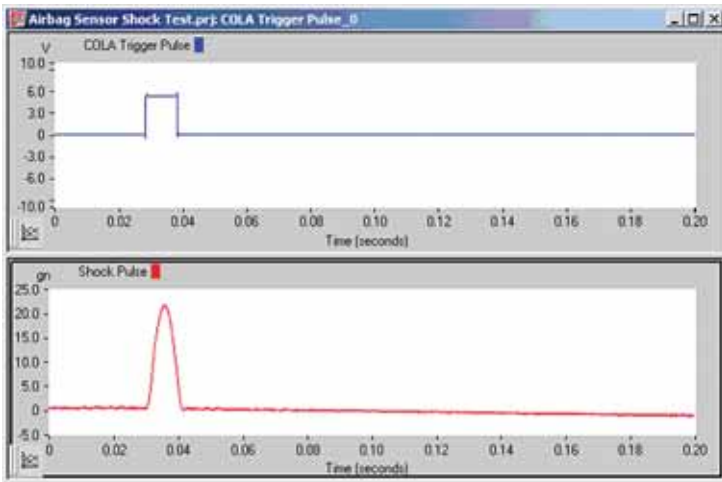

Figure 4. The COLA output from the vibration controller is a TTL type of pulse that acts as a trigger for starting data acquisition on the PC measurement system. The start of the COLA output pulse is adjustable relative to the shock pulse output so that the trigger event occurs just before or coincident with the start of shock pulse.

As shown in Figure 5, the vibration controller is integrated with the shaker positioning system and data acquisition system in a standard equipment rack.



Figure 5. The LDS-Dactron Laser controller is integrated into a 19" instrumentation module, together with the main indicators to monitor the operation of the shaker.

4) Galvanic Separation

Two isolation amplifiers with high-bandwidth have been used to isolate the AC and DC signals from the power amplifier. For the COLA output a dedicated isolation module has been designed to avoid problems with ground loops. This practice ensures galvanic separation between the three building blocks: the control system, the power amplifier, and the measurement system.

Conclusion

Engineers can now simplify and automate testing by using ActiveX programming tools to efficiently integrate systems for vibration control, shock testing and high-speed measurement. Such software-based solutions eliminate the inflexible and error prone approach of using dedicated hardware boxes with manual coordination by test operators. The result is a reliable test bench where the complexity and flexibility of the test set-up is integrated into the software as opposed to a special, inflexible hardware solution.

For networked communication, the serial interface to higher level measurement systems can be replaced by TCP/IP protocol. This approach allows implementation of a LAN-based solution with multiple PC's or integration into a single PC.

For more information:

Quality Electronics Design S.A.
Email: ben.haest@qed.lu
Web: www.qed.lu or

LDS-Dactron
Email: sale@lds.spk.com
Web: www.lds-group.com

sales@lds.spk.com

www.lds-group.com



USA
LDS Test and Measurement LLC
8551 Research Way, M/S 140
Middleton, WI 53562
Tel: +1 608 821 6600
Fax: +1 608 821 6690

Europe/International
LDS Test and Measurement Ltd
Heath Works, Baldock Road,
Royston, Herts,
SG8 5BQ, England
Tel: +44 1763 242424
Fax: +44 1763 249715

SPX Corporation